

Motivi Collection, News N°1.

Models: *Harvey, Fly*



Un nome di famiglia.
Alberta nasce nel 1978 dall'intuizione di Giuseppe Sbroggiò: unire la migliore sapienza artigianale italiana con la cultura contemporanea del design, in un brand dedicato al pubblico internazionale. È l'inizio di una storia di successo, un viaggio che continua attraverso il tempo e le generazioni. I figli Riccardo e Vittorio, insieme all'intera squadra aziendale, contribuiscono con la loro professionalità e il loro entusiasmo a rendere Alberta protagonista di uno stile originale di vita e d'arredo.



A family name.
Alberta was founded in 1978 from a Giuseppe Sbroggiò initiative: to unite the best Italian craftsmanship with contemporary design culture in a brand dedicated to an international audience. It is the beginning of a success story, a journey that continues through time and generations. With their professionalism and enthusiasm, sons Riccardo and Vittorio, together with the entire company team, help to give Alberta the leading role when it comes to having an original style in life and in furniture.



Made in Italy.
Nell'operoso Nord Est d'Italia, fra verdi colline patrimonio dell'UNESCO, l'antica tradizione rurale si intreccia con l'influsso artistico e storico di Venezia. In questo territorio unico al mondo, si svolge l'intero processo produttivo di Alberta: una sintesi di antica manualità, tecnologie moderne e innovazioni esclusive. Alberta dialoga con designer affermati sulla scena italiana e internazionale, promuovendo inoltre i nuovi talenti, in collaborazione con lo IUAV di Venezia e il Politecnico di Milano.

Made in Italy.
In the industrious North East of Italy, among the green hills, a UNESCO heritage site, the ancient and rural tradition is intertwined with the artistic and historical influence of Venice. In this unique part of the world, the entire Alberta production process takes place: a combination of ancient craftsmanship, modern technologies and exclusive innovations. Alberta works with established designers on the Italian and international scene, also supporting new talents, in collaboration with the IUAV of Venice and the Polytechnic of Milan.

MOTIVI, COLLECTION.

HARVEY
Design, Alberta Style Department



Harvey esprime un concetto di design originale, per uno stile di vita oltre i luoghi comuni: anche nell'ergonomia. Gli schienali sono infatti dotati di un meccanismo azionabile con un semplice gesto della mano, oppure con un tocco sul telecomando, per un comfort personalizzato al millimetro. La profondità della seduta consente di utilizzarla anche come una chaise longue. Le cuciture perimetrali a cordoncino aggiungono un dettaglio di raffinata sartorialità.

Come i divani Harvey, anche i tavolini Cloud, con le loro forme organiche, possono essere utilizzati singolarmente, oppure dare vita a composizioni affiancate, con una totale libertà di ambientazione e d'uso.

Harvey expresses an original design concept for a lifestyle beyond clichés, even in ergonomics. The backrests are in fact equipped with a mechanism that can be operated with a simple hand gesture, or with a touch of the remote control, for comfort personalised down to the last millimetre. The depth of the seat also allows it to be used as a chaise longue. The perimeter cord seams add a refined tailoring detail.

Like the Harvey sofas, the Cloud coffee tables, with their organic shapes, can be also used individually or to create side-by-side compositions, with total freedom of setting and use.

FLY
Design, Alberta Style Department



La leggerezza è la parola chiave di Fly, un progetto fatto di forme essenziali e volumi compatti, in armonia con la filosofia estetica e le esigenze pratiche della casa contemporanea. I piedini cilindrici sollevano il divano da terra, creando un effetto dinamico e al tempo stesso facilitando la pulizia del pavimento. La sua modularità consente di creare le più diverse soluzioni compositive, ottimizzando lo spazio a disposizione.

Calore naturale e dinamismo contemporaneo per i tavolini Island, con piani in noce o rovere scuro realizzati con sapienza artigianale e abbinati a strutture metalliche. Il gioco delle venature crea un effetto grafico fra natura e contemporaneità. Le loro altezze diverse consentono di utilizzarli in composizioni multiple oppure come elementi singoli di servizio.

Lightness is the keyword of Fly, a project made up of essential shapes and compact volumes, in harmony with the aesthetic philosophy and practical needs of the contemporary home. The cylindrical feet raise the sofa from the floor, creating a dynamic effect and making it easier to clean the floor at the same time. Its modularity allows you to create the most diverse compositional solutions, optimising the space available.

Natural warmth and contemporary dynamism for the Island coffee tables, with walnut or oak tops made with expert craftsmanship and combined with metal structures. The interplay of veining creates a graphic effect between nature and contemporaneity. Their different heights allow them to be used in multiple compositions or as single service elements.



















Calore naturale e dinamismo contemporaneo per i tavolini Island, con piani in rovere scuro o noce canaletto realizzati con sapienza artigianale e abbinati a gambe metalliche disponibili in 3 altezze. Il gioco delle venature crea un effetto grafico fra natura e contemporaneità. Le loro altezze diverse consentono di utilizzarli in composizioni multiple oppure come elementi singoli di servizio.

Natural warmth and contemporary dynamism for the Island coffee tables, with tops in dark oak or canaletto walnut made with expert craftsmanship and combined with metal legs available in 3 heights. The interplay of veining creates a graphic effect between nature and contemporaneity. Their different heights allow them to be used in multiple compositions or as single service elements.













Divano / Sofa
2FLAD3

Pelle / Leather
5B130 BOB Blu, Cat. F.



MOTIVI, TECHNICAL.

<p>Struttura portante: Multistrato e massello di legno.</p>	<p>Main structure: Multilayer and solid wood.</p>
<p>Imbottiture: Cuscino di schienale in poliuretano espanso rivestito in fibra di poliestere. Seduta e scocca in poliuretano espanso a densità differenziata rivestito in fibra di poliestere. Bracciolo in poliuretano espanso rivestito in fibra di poliestere.</p>	<p>Upholstery: Backrest cushion in polyurethane foam covered with polyester fiber. Seat and chassis in polyurethane foam with different densities covered with polyester fiber. Armrest in polyurethane foam covered with polyester fiber.</p>
<p>Molleggio: Cinghie elastiche in polipropilene e gomma.</p>	<p>Suspensions: Elastic belts in polypropylene and rubber.</p>
<p>Meccanica: Schienale regolabile con meccanismo elettrico (100-240 V - 50/60 Hz) comandato con telecomando o meccanismo manuale. Posizione dello schienale a proprio piacimento.</p>	<p>Mechanics: Adjustable backrest with electric mechanism (100-240 V - 50/60 Hz) controlled by a remote control or with manual mechanism. Backrest position as desired.</p>
<p>Piedino: ABS.</p>	<p>Feet: ABS.</p>

ERGONOMIA / ERGONOMIC

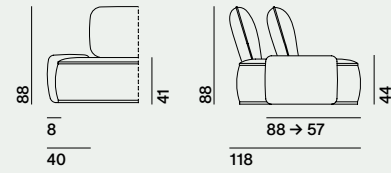

1HRVD3ME Electric, 1HRVD3MM Manual

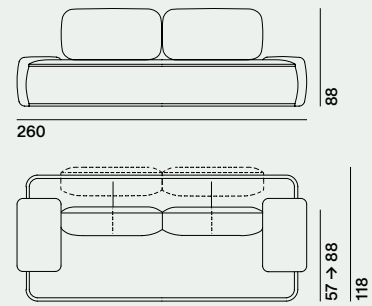

1HRVD2MME Electric, 1HRVD2MMM Manual

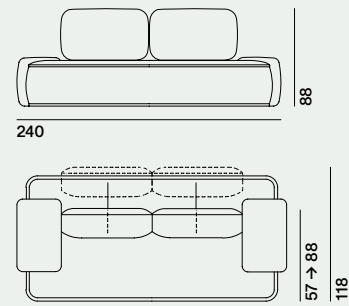

1HRVD3MESX Electric, 1HRVD3MMSX Manual

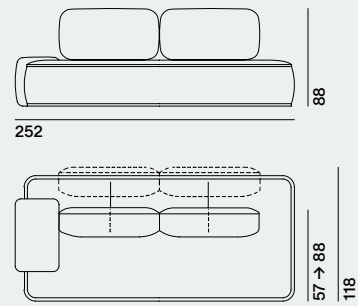

1HRVD2MMESX Electric, 1HRVD2MMSX Manual

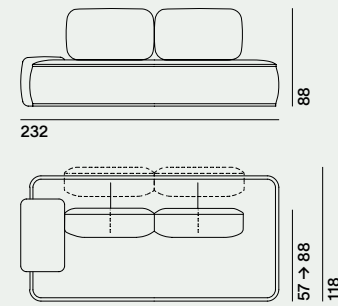

1HRVMIRMESX Electric, 1HRVMIRMMSX Manual

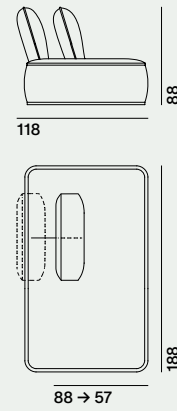

1HRVMERMEDX Electric, 1HRVMERMMDX Manual

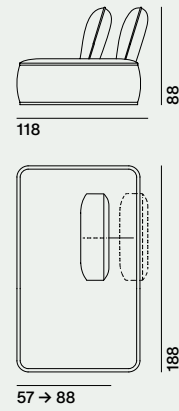

1HRVD3ME1 Electric, 1HRVD3MM1 Manual

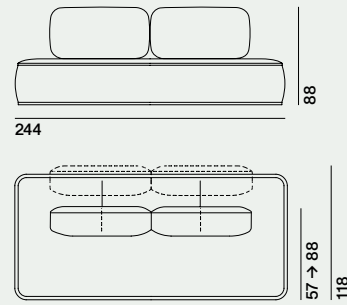

1HRVD2MME1 Electric, 1HRVD2MMM1 Manual

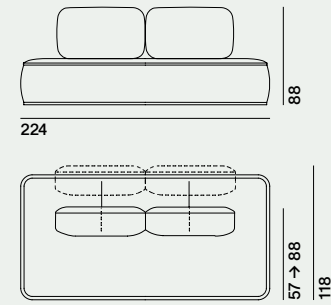

1HRVPM1 Electric, 1HRVPM1 Manual

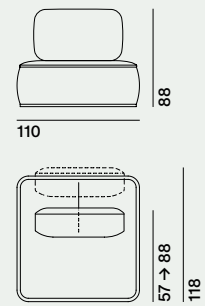

1HRVPOUFF

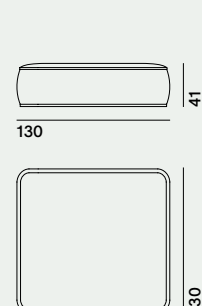

01HRVC1 (1HRVD3MESX + 1HRVPOUFF + 1HRVMERMEDX)

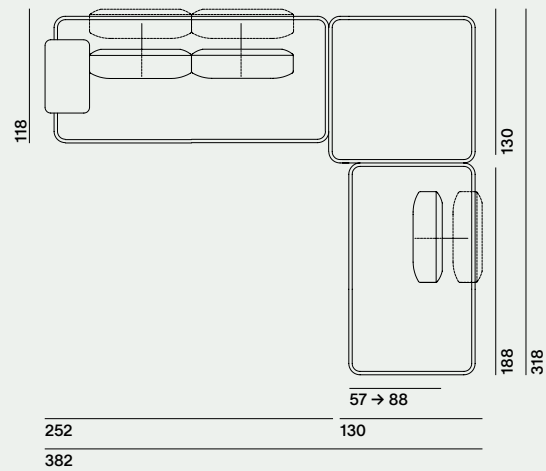

<p>Struttura portante: Multistrato, massello di legno</p>	<p>Main structure: Multilayer and solid wood.</p>
<p>Imbottiture: Cuscino di schienale in piuma d'oca e fibra di poliestere, rivestito in tela di cotone. Cuscino di seduta in poliuretano espanso rivestito in fibra di poliestere accoppiata a vellutino. Scocca e bracciolo in poliuretano espanso.</p>	<p>Upholstery: Backrest cushion in goose feather and polyester fiber, covered with cotton fabric. Seat cushion in polyurethane foam covered with polyester fiber coupled with elastic velvet. Chassis and armrest in polyurethane foam.</p>
<p>Molleggio: Cinghie elastiche in polipropilene e gomma.</p>	<p>Suspensions: Elastic belts in polypropylene and rubber.</p>
<p>Piedino: Metallo.</p>	<p>Feet: Metal.</p>
<p>Cod. Tessuto: 1 / 01 Cod. Pelle: 2 / 02</p>	<p>Cod. Fabric: 1 / 01 Cod. Leather: 2 / 02</p>

ERGONOMIA / ERGONOMIC

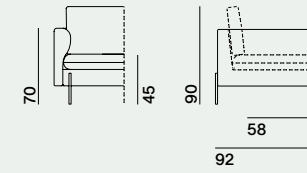

1FLAD3, 2FLAD3

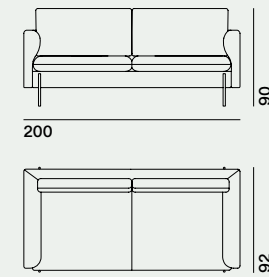

1FLAD2M, 2FLAD2M

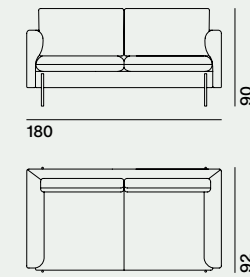

1FLAD2, 2FLAD2

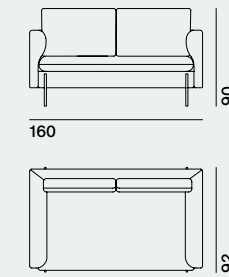

1FLAP, 2FLAP

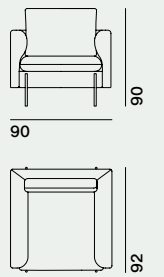

1FLAD3SX, 2FLAD3SX

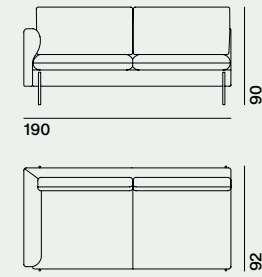

1FLAD2MSX, 2FLAD2MSX

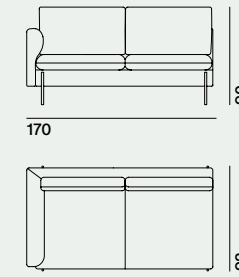

1FLAD2SX, 2FLAD2SX

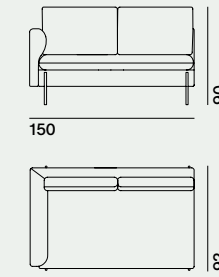

1FLAPSX, 2FLAPSX

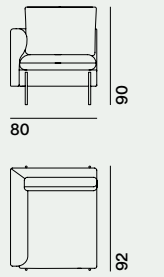

1FLACHLSX, 2FLACHLSX

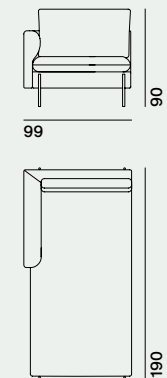

1FLACHLSX, 2FLACHLSX

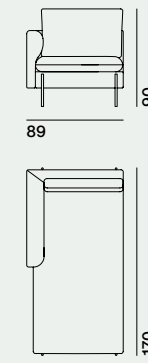

1FLAESP1SX, 2FLAESP1SX

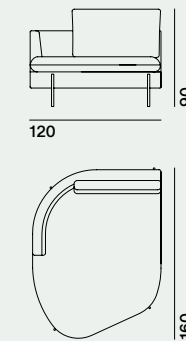

1FLAAP, 2FLAAP

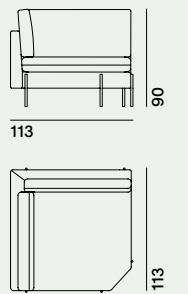

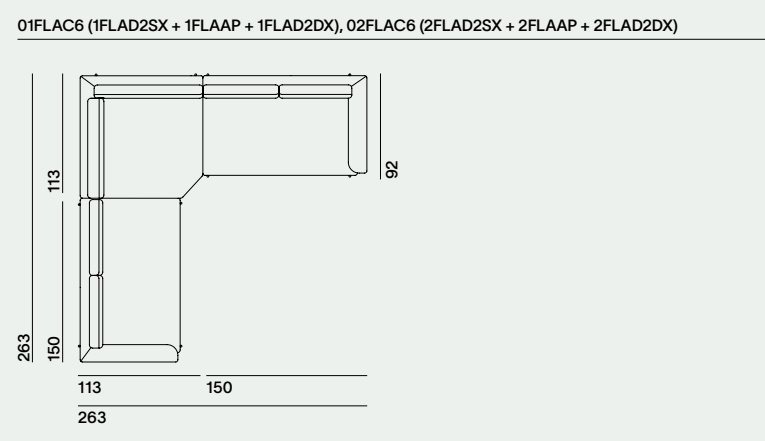
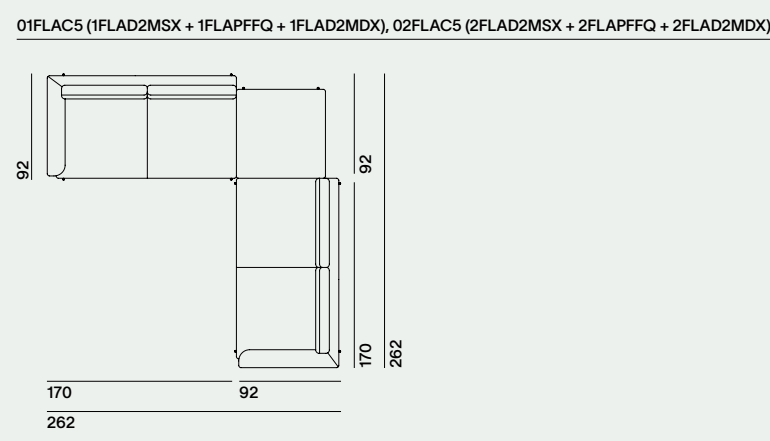
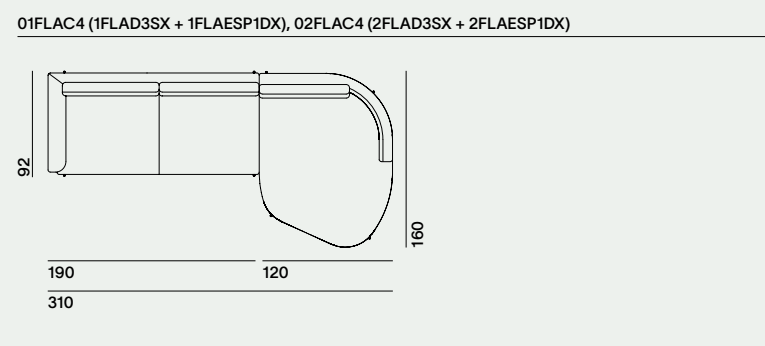
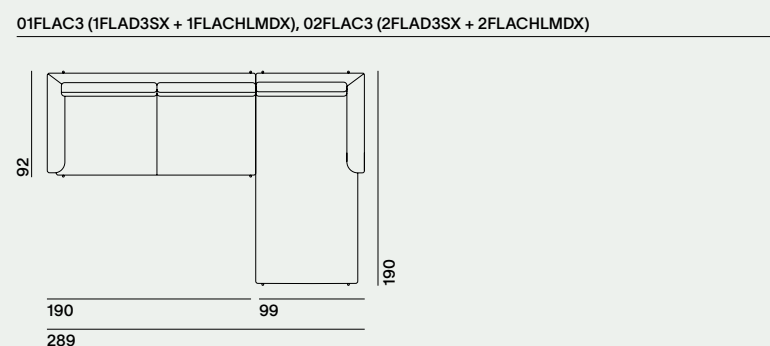
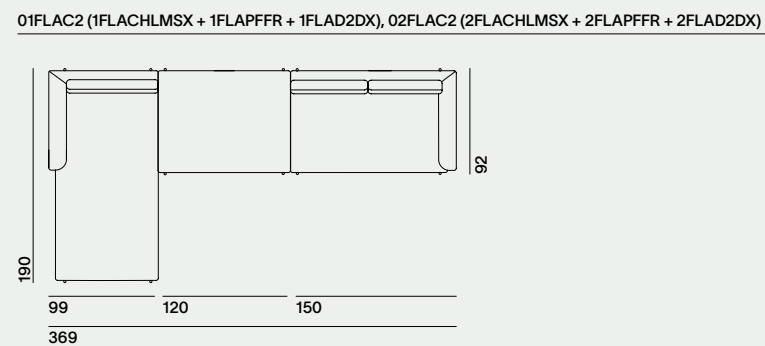
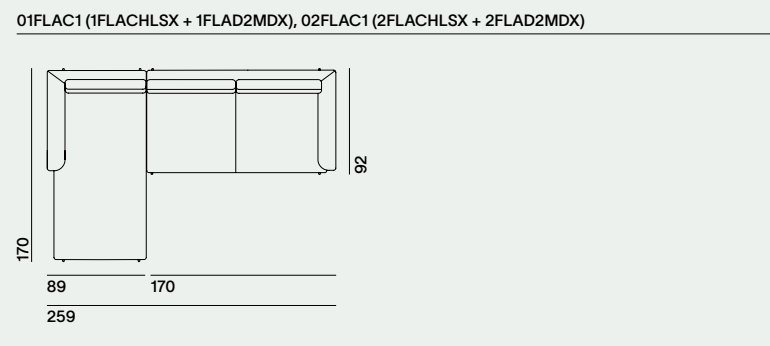
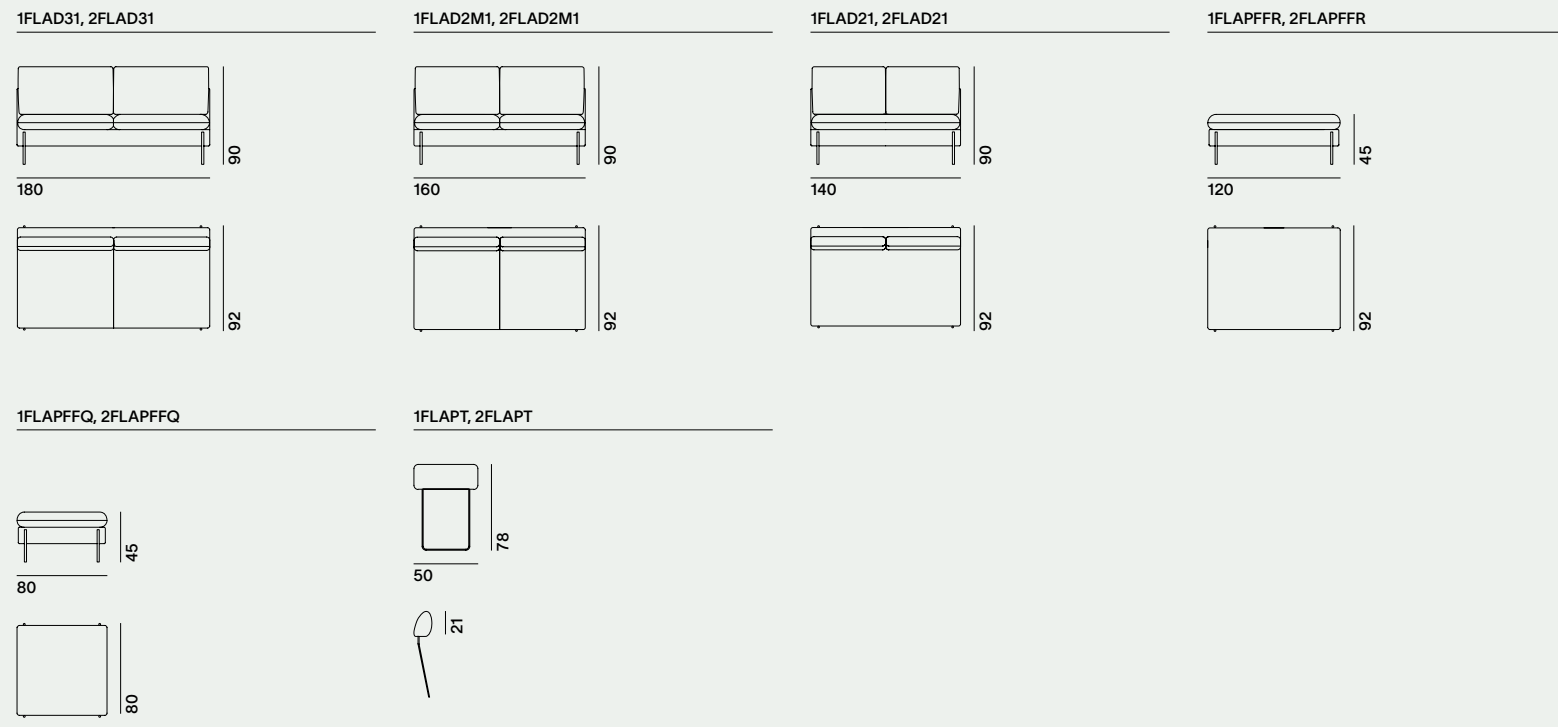

CLOUD, Alberta Style Department

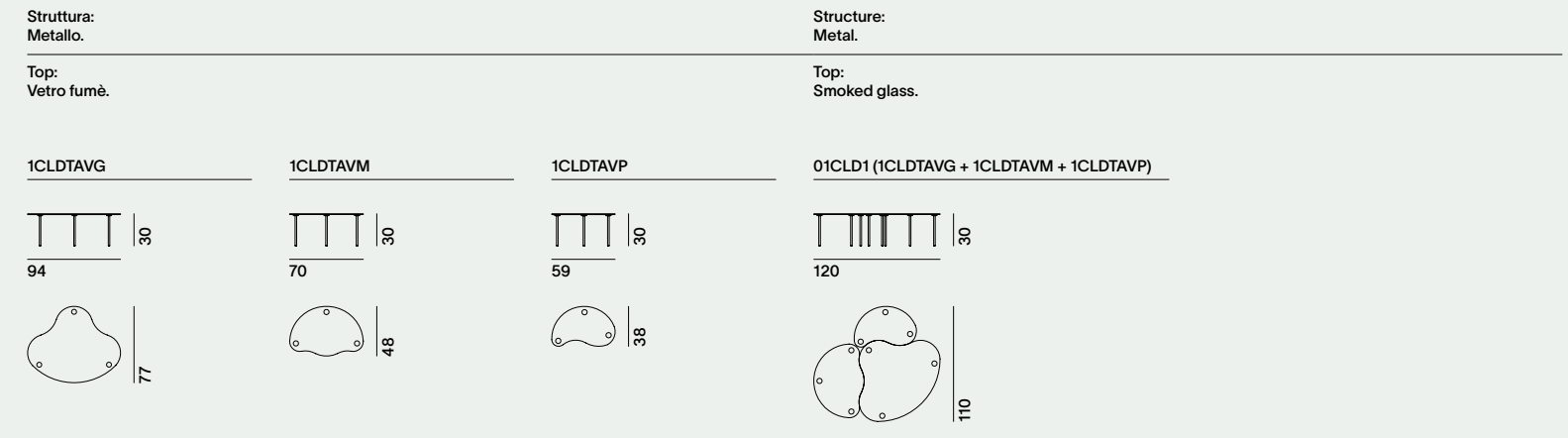

FLYNN, Maurizio Manzoni – Studio Memo

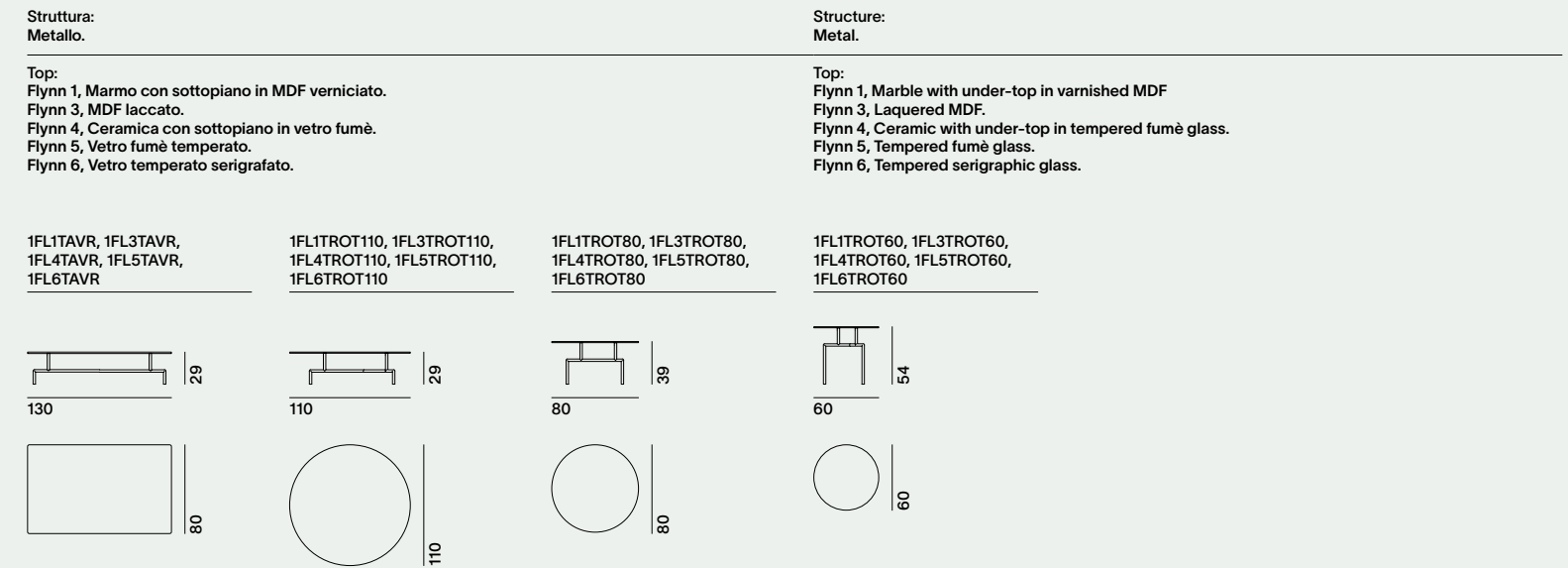

ISLAND, Castello Lagravinese Studio

Struttura: Metallo. Structure: Metal.

Top: MDF impiallacciato. Top: Veneer MDF.

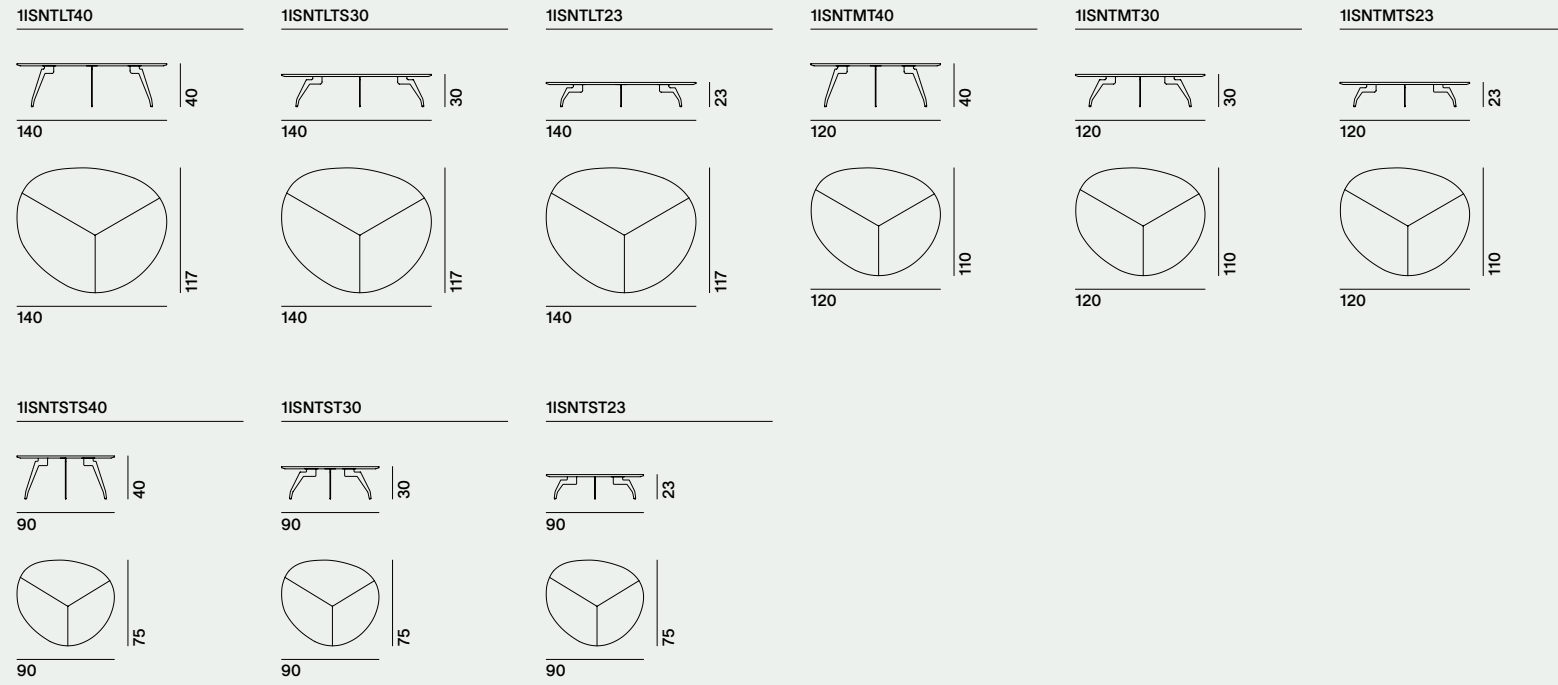

RODEO 1 - 3 - 5, Yonoh Creative Studio

Struttura: Metallo. Structure: Metal.

Top Rodeo 1: Marmo. Top Rodeo 1: Marble.

Top Rodeo 3: MDF laccato. Top Rodeo 3: Lacquered MDF.

Top Rodeo 5: Vetro fumè. Top Rodeo 5: Smoked glass.

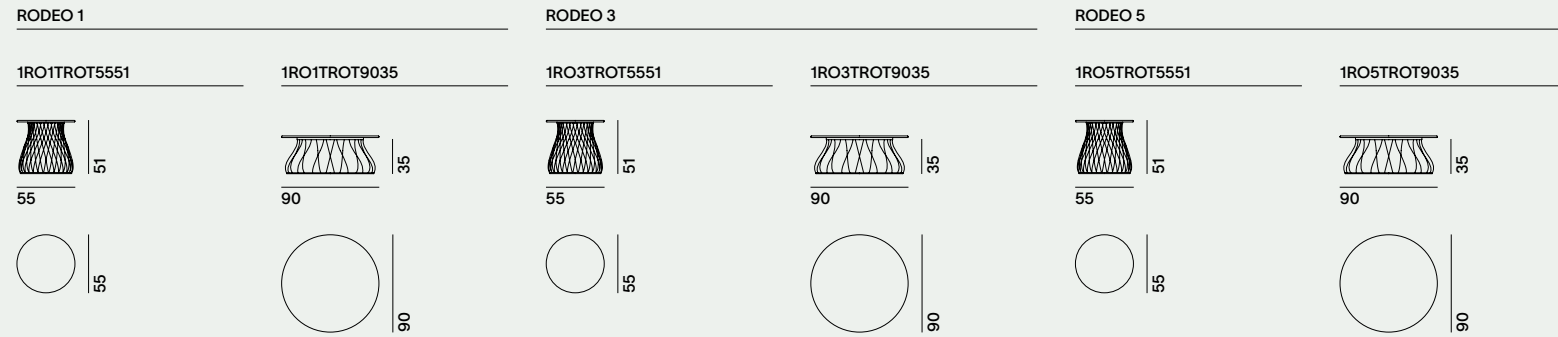

Alberta Pacific Furniture Spa
via Toniolo N°41
31028 Vazzola (TV) — Italy

T +39 0438 440440
F +39 0438 441555

alberta@alberta.it
www.alberta.it

alberta[®]
Made in Italy

AD, Graphics e Concept → Cristian Malisan / Studio Malisan;
Layout → Gianluca Cumin / Studio Malisan;
Images → Flavio Favero / Studio Emozioni;
Styling → Beppe Mangia / EYE – Studio;
Text → Daniele Varelli.

Thanks to Paola Paronetto.

03.2023

